

DISTRICT OF MAPLE RIDGE

BYLAW NO. 6800-2011

A bylaw to regulate the disposal of solid waste and recyclable materials within the District of Maple Ridge

WHEREAS the District of Maple Ridge has entered into an agreement with Metro Vancouver whereby the latter is responsible for providing for the disposal of waste materials originating within the Municipality;

NOW THEREFORE the Municipal Council of the District of Maple Ridge, in an open meeting assembled, ENACTS AS FOLLOWS:

1. This bylaw may be cited as “District of Maple Ridge Solid Waste and Recycling Regulation Bylaw No. 6800-2011.
2. **Definitions** - The following words and phrases shall have these designated meanings:

Acceptable wastes are:

- (a) Kitchen and table wastes, clothing, leather, crockery, glassware, pallets and any other material of a like nature.
- (b) Lumber, demolition materials, earth fill, broken concrete and asphalt, bricks, gyproc cuttings, small stumps and timbers and any other material of a like nature from typical homeowner redevelopment and construction projects;

Collection day means the day scheduled for collection of solid waste, food scraps and recyclable material from a property in accordance with the schedule produced annually by the Recycling Society or other delegate appointed by Council or a private contractor providing such service to the property;

Construction and Demolition Waste means all earth, debris, rocks, trees, stumps, building materials and anything else originating from the construction and demolition of buildings and structures;

Dangerous wildlife means any mammal not normally domesticated capable of killing or seriously injuring a person or pet, and includes bears, cougars, coyotes, wolves and foxes;

Household Receptacle means a plastic bag, metal or plastic garbage can that:

- (a) is strong enough to withstand normal handling and lifting
- (b) when full, has a gross weight not exceeding 20 kg
- (c) is closed and sealed
- (d) contains no glassware, bottles or sharp pieces of wood or metal that might tear the bag or a plastic or galvanized iron or other rust resisting metal container having a volume not exceeding 77 litres and, when full, a gross weight not exceeding 20 kg
- (e) a shape and opening that permits emptying with minimum effort

- (f) handles or handling devices that enable the container to be lifted and emptied safely by one person
- (g) a watertight, removable cover;

Light commercial receptacle means a plastic garbage bag, metal or plastic garbage can that:

- (a) is strong enough to withstand normal handling and lifting
- (b) when full, has a gross weight not exceeding 20 kg
- (c) is closed and sealed
- (d) contains no glassware, bottles or sharp pieces of wood or metal that might tear the bag or a plastic or galvanized iron or other rust resisting metal container having a volume not exceeding 77 litres and, when full, a gross weight not exceeding 20 kg
- (e) a shape and opening that permits emptying with minimum effort
- (f) handles or handling devices that enable the container to be lifted and emptied safely by one person
- (g) a watertight removable cover;

Mixed-Use means a multi-family dwelling combined with commercial use building on the same property;

Multi Family Dwelling means a detached, multi floor building containing three or more residential dwelling units including but not limited to an apartment complex, townhouses and condominiums;

Owner means an owner as defined in the Community Charter;

Receptacle means a household, light commercial, municipal, yard waste or special receptacle;

Recyclable Materials means a product or substance no longer usable in its current state which can be diverted or recovered from solid waste and used in the processing or manufacture of a new product and, without limiting the foregoing, includes paper, cardboard, plastic or metal containers, household batteries (including rechargeable batteries) and materials recyclable under a product stewardship plan established under the *Recycling Regulation to the Environment Management Act*, S.B.C. 2003, ch. 53;

Special Waste means hazardous wastes, pathological wastes, explosives, radio-active material, security wastes, confidential documents, negotiable papers, medical wastes and includes all wastes resulting from any industrial or manufacturing operations, the construction or demolition of buildings and structures, abandoned vehicles and parts thereof, dead animals, and all animal parts and agricultural wastes and any hazardous waste, or other prescribed substance, under contaminated sites legislation in the Province of British Columbia and includes material regulated as “special waste” by the *Environmental Waste Management Act* of the Province of British Columbia;

Solid Waste means waste that originates from residential, commercial, institutional, landscaping, demolition, land clearing or construction sources within the District;

Unacceptable waste means:

- (a) Lumber, demolition materials, earth fill, broken concrete and asphalt, bricks, gyproc cuttings, stumps and timbers and any other material of a like nature from construction projects larger than those defined in (b) under “**Acceptable Waste**”;
- (b) Automobiles and trucks, tires in quantity, agricultural waste, dead animals or fish, wet-cell batteries, all liquid wastes (paints, thinners, chemicals, etc.), sewage, septic tank pumpage, hazardous waste, special waste, pathological and infectious waste and any other material or substance which Metro Vancouver may from time to time determine;
- (c) Special Waste;

Waste Material means all waste other than green waste and recyclables but shall not include special waste, construction, demolition or land clearing waste, animal or human feces, animal carcasses or their parts, car parts or furniture;

Wildlife attractant means food products and by-products, household garbage, food waste, pet food, bird food, antifreeze, paint and other edible products, recyclable products or waste that could attract Dangerous Wildlife;

Wildlife resistant enclosure means a fully enclosed structure consisting of walls, roof, and door(s), capable of being securely latched and of sufficient strength and design to prevent access to the contents of wildlife;

Yard Waste means house plants, weeds, plants, leaves, grass, hedge and plant clippings, lawn edgings, twigs and branches up to four (4) inches in diameter, but does not include land clearing waste;

Yard waste receptacle means a bag or container that:

- (a) is strong enough to withstand normal handling and lifting;
- (b) that is made of transparent non-coloured plastic or, in the case of a container, has affixed to it a ‘Yard Trimmings’ label provided by the Ridge Meadows Recycling Society or delegate appointed by Council;
- (c) when full, has a gross weight not exceeding 20 kg;
- (d) has a volume not exceeding 77 litres;
- (e) is closed and sealed;
- (f) contains only yard waste

General

3. Every owner or occupier of a dwelling must recycle by placing recyclable materials into a recycling receptacle without contamination.
4. No garbage or plastic bags shall be placed in a recycling receptacle or yard waste container.

5. Every owner or occupier of a dwelling shall at all times maintain all receptacles supplied by the Ridge Meadows Recycling Society or delegate as appointed by Council in a clean and sanitary condition, without overflow and free from any liquids.
6. No person shall remove, take or convert to their own use any solid waste, yard waste or or recyclable materials from a solid waste receptacle, yard waste receptacle or a recycling receptacle except the owner or occupant of the property from which it is generated, the remover or a person providing the collection service at the request of the owner or the occupant.
7. Notwithstanding anything contained in this Bylaw any non-profit society may carry out bottle or newspaper drives without further permission from the District.

Recycling Facility & Transfer Station

8. That parcel of land known and described as:

Parcel B of Lot 17 District Lot 275 Group 1 Plan 7587 New Westminster District

Is hereby designated and established for the deposit of recyclable material and acceptable wastes as defined herein.

9. The Council may, by resolution, from time to time designate other lands in addition to or in substitution for the lands described in Section 4 hereof for the deposit or disposal of waste.
10. The Ridge Meadows Recycling Society, or other designate appointed by Council, their agents, servants and employees are designated and authorized to sort, collect and remove salvage or waste material from the designated property.
11. Every owner or occupier of a dwelling shall place solid waste and recycling receptacles at a point on the shoulder of the road or lane or adjacent to the curb in front of their premises or on their premises adjacent to the property line abutting the street or lane from which such collection service is provided no earlier than 10:00 p.m. the day before collection day and no later than 7:00 a.m. on collection day. All receptacles shall be placed in such a position so as to be conveniently handled from ground level and readily accessible from such street, lane or sidewalk, and all such receptacles shall be removed from the street or lane allowance no later than 6:00 p.m. on collection day.
12. No person shall sort, collect or remove any salvage or waste material from the designated property as set out in section 8.
13. Ratepayers of the Municipality of Maple Ridge or their agents, servants and employees may deposit acceptable waste which originates from within the boundaries of the Municipality of Maple Ridge at the location indicated in or upon the designated property as set out in section 8, during the days and hours the Ridge Meadows Recycling Society is open to the public provided that such wastes are transported to the designated property in cars, station wagons, cars with trailers, and up to and including 1 tonne trucks with standard box height. Wastes other than hazardous or special wastes transported in vehicles other than these may be deposited at 1200 United Boulevard, Coquitlam (currently known as Wastech Services Ltd.).
14. No person shall deposit or suffer or permit to be deposited any icebox, refrigerator, freezer or other container equipped with any latch or locking device in or upon the designated property without first

removing or rendering inoperable such latch or locking device so that the door or lid thereof cannot be held in closed position.

15. Acceptable solid waste may be deposited at the Transfer Station located at the designated property as set out in section 8 of this bylaw.

Garbage and Recycling Facilities for Multi Residential and Mixed use Buildings

16. Every owner or occupier of multi residential or mixed use buildings shall provide adequate facilities for garbage and recycling container storage. The storage area must meet current BC Building Code Regulations. (Reference: Section – Service Rooms).

Container Requirements – Multi-family and Mixed Use Buildings Recyclable Materials Collections Service

17. For the purposes of this Bylaw every owner or occupier of multi-family and mixed use buildings shall comply with the following regulations:

Collection

Building management must contact the District's Recycling Program office (telephone 604-463-5545) upon occupancy to implement the recycling system. Recycling systems will be designed to fit the needs of each building.

Basic Requirements

More than 12 units will use the set of 6 *Recycling Cart System (Figure 1)*

Twelve (12) units or less will use the *Blue Box Rack System*

More than 60 units will require nine (9) *Recycling Carts*

More than 100 units will require fourteen (14) *Recycling Carts* (

Each residential unit *is issued two (2) Plastic Recycling Tote Bags (Figure 2)*

Minimum of one recycling station area per building serviced once or twice per week.

Recycling Storage Location

Close to garbage area (room), within a reasonable distance (suggested minimum 1.52 m - 5 feet) from garbage container for loading purposes.

Container Size

The container size and measurements are:

RECYCLING CART SYSTEM - Figure 1 (See Schedule A)

#	<u>Tote Size</u>	<u>Height</u>	<u>Width</u>	<u>Diameter</u>
2	360 litres (95 gallons)	118.11 cm (46.5")	71.12 cm (28")	78.74 cm (31")
2	246 litres (65 gallons)	107.18 cm (42.2")	66.04 cm (26")	68.07 cm (26.8")
2	132 litres (35 gallons)	97.79 cm (38.5")	57.78 cm (22.75")	56.76 cm (22.35")

Container Access (Reference Figure 1)

Loaded from top. Resident is responsible for placing sorted recycling in containers. Minimum added clearance. Height of 81.3 cm (32") is required for lid opening.

Unit Containers (Reference: Figure 2)

Individual residential units have two (2) plastic recycling tote bags for temporary storage of recycling in the unit prior to transporting to the recycling sorting station.

PLASTIC RECYCLING TOTE BAG - Figure 2 (See Schedule A)

#	<u>Size</u>	<u>Height</u>	<u>Width</u>
2	17 litres (4.5 gallons)	50 cm (19.68")	48 cm (18.89")

Collection Access

Building Managers are required to roll the Recycling System Containers out to curb side on collection day. Collection staff will provide curb side collection from containers. A security access code or a lock box key must be issued to Ridge Meadows Recycling Society or delegate appointed by Council.

Trucks

Collection vehicles are:

<u>Height</u>	<u>Length</u>	<u>Width</u>
3.66 m (12 feet)	8.84 m (29 feet)	2.44 m (8 feet)

with a turning radius of 20.6 m (67.6 feet)

Materials collected

Containers are colour-coded as follows:

BLUE - Newspaper

YELLOW - Cardboard

GREEN - Office Paper and Magazines

ORANGE - Cans – tins and aluminum, milk cartons

WHITE - Glass – bottles and jars

PINK - Plastic containers #1, #2, #4, #5, and plastic bags #4

Single Family and Two Family Dwellings Recyclable Materials Collection Service

Owners and occupiers of single and two family dwellings shall comply with the following regulations:

Materials collected

Bags are colour-coded as follows:

BLUE - Newspaper

YELLOW - Cardboard

GREEN - Office Paper and Magazines

ORANGE - Cans – tins and aluminum, milk cartons

WHITE - Glass – bottles and jars

PINK - Plastic containers #1, #2, #4, #5, and plastic bags #4

18. Any person who violates any of the provisions of this Bylaw or who suffers or permits any act or thing to be done in contravention or in violation of any of the provisions of this Bylaw or who neglects to do or refrains from doing anything required to be done by any of the provisions of this Bylaw, shall be deemed to be guilty of an offence thereof and is punishable in accordance with the *Offence Act*. Where an offence against this Bylaw is of a continuing nature, it shall be lawful to impose a fine or penalty not exceeding Two Thousand Dollars (\$2,000.00) and costs for each day such offence is continued by the offender. Where the offense is a continuing one, each day that the offence is continued shall constitute a separate offence.

19. If any section, subsection or clause of the Bylaw is declared or held to be invalid by a Court of competent jurisdiction, then that invalid portion shall be severed and the remainder of the Bylaw shall be deemed to have been enacted and adopted without the invalid and severed section, subsection or clause.

20. That Maple Ridge Garbage Disposal Regulation By-Law No.4222-1989 including any amendments thereto be repealed in its entirety.

21. Schedule A is attached to and forms part of this Bylaw.

READ A FIRST TIME this 12th day of April, 2011.

READ A SECOND TIME this 12th day of April, 2011.

READ A THIRD TIME this 12th day of April, 2011.

ADOPTED this 26th day of April, 2011.

PRESIDING MEMBER

CORPORATE OFFICER

SCHEDULE A

RECYCLING CART SYSTEM – FIGURE 1

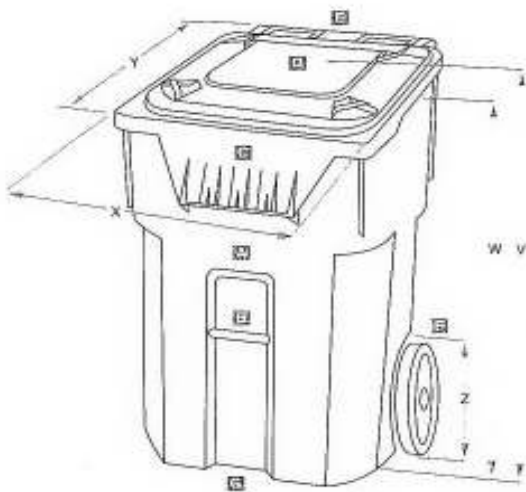

Dimensions		USD 35	USD 65	USD 95
Overall Height	V	38.5"	42.2"	46.5"
Cart Body Height	W	35.8"	39.5"	43"
Overall Width	X	22.75"	25"	28"
Overall Depth	Y	22.36"	26.8"	30.5"
Wheel Diameter	Z	8"	8" or 10"	12"

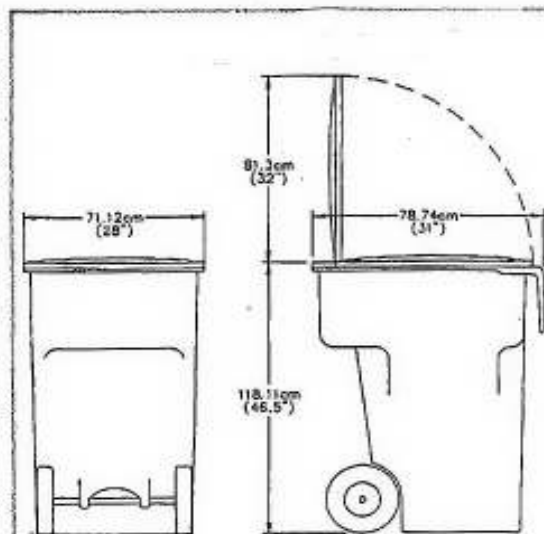

360 LITRE (95 GALLON) RECYCLING CART

SCHEDULE A cont'd

PLASTIC RECYCLING TOTE BAG - FIGURE 2

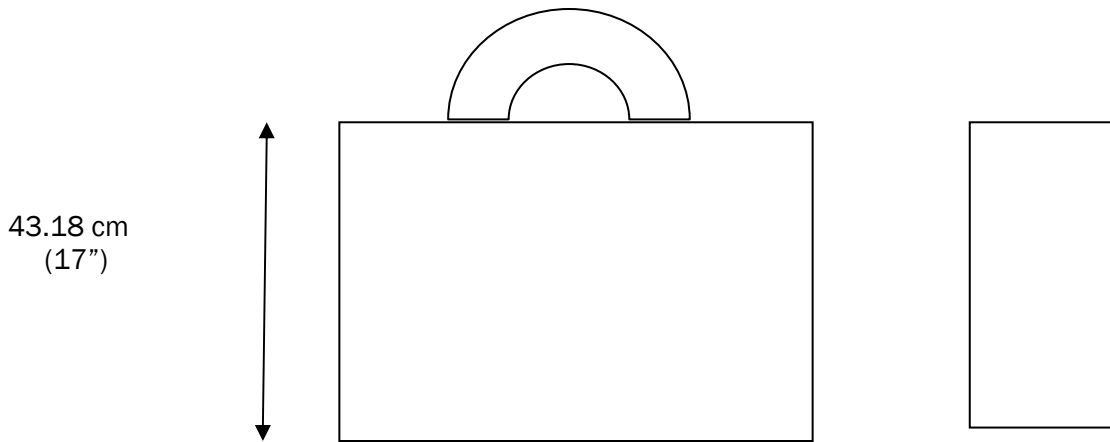

SCHEDULE A cont'd

**WASTE MANAGEMENT GUIDELINES FOR
MULTIPLE-FAMILY RESIDENTIAL AND MIXED USE BUILDINGS**

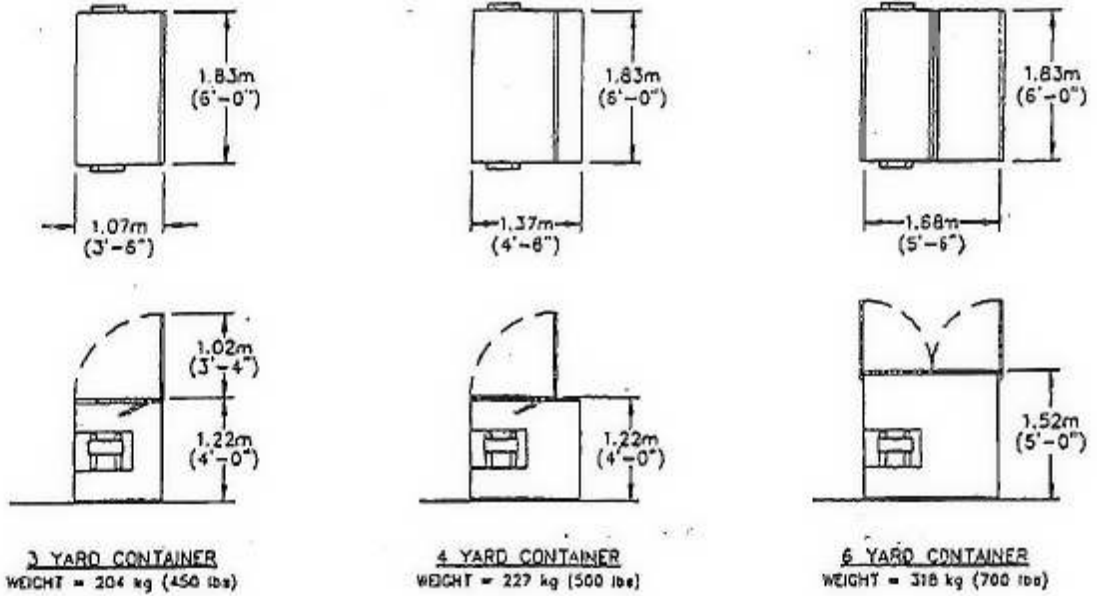

NOTE: If container is on wheels, an additional height of 12.7cm - 15.24cm (5" - 6") is required.